

Guatemala, 26 de noviembre de 2021

Licenciado
Luis Adolfo Mijangos Recinos
Director General de las Artes
Ministerio de Cultura y Deportes
Su despacho

Dirección General de las Artes

RECEPCIÓN

RECIBIDO
26 NOV 2021

Recibe: Andrés Hora: 08:50
Correlativo No. 5045/6
Nota _____

Estimado Licenciado Mijangos:

De la manera más atenta me dirijo a usted con el propósito de presentarle mi informe de actividades conforme a lo estipulado en el **Contrato Administrativo Número DGA-187-1073-2021 Resolución VC-DGA-169-2021**, por servicios Técnicos correspondientes al primer producto e informe.

ACTIVIDADES

1. Se apoyó en la continuidad de la acción creativa y técnica de la obra musical "Inframundo: Descenso y Ascensión";
2. Se apoyó en la obra los "Negro violines de Dubus" (para diez violines solos) dividiéndolo en diferentes movimientos musicales de acuerdo a su género coral sinfónico;
3. Se brindó apoyo en el desarrollo del grupo de cámara de la obra "Negro violines de Dubus" (para diez violines solos);
4. Se apoyó en la continuidad de la "Multifonalia" (útil sonoro); que se realiza por medio de útiles sonoros y voces al arte de performance;
5. Se apoyó en la elaboración de útiles sonoros y su uso en la Multifonalia" (útil sonoro);
6. Se brindó apoyo en la elaboración y experimentación de la composición de los diferentes movimientos musicales;
7. Se apoyó en la elaboración de la escritura y traficación de la partitura correspondiente a cada obra; y

PRODUCTO No. 1

Informe sobre los avances de la acción creativa y técnica de la obra musical “Inframundo: Descenso y Ascensión” y la obra los “Negro violines de Dubus”.

RESULTADOS

- Se brindó apoyo a la Obra Musical “Inframundo: Descenso y Ascensión” para ocho violonchelos, seis contrabajos, Útiles sonoros y veinte voces femeninas. La obra expresa profundidades terráqueas (grandes cavernas y sus abismos). Está referida a las ciudades Mayas de “Xibalbá”, que según leyendas, están bajo tierra.
 - Se apoyó en el descenso en la obra lo describen los 8 violonchelos en los grandes glissandos desendiendo hacia el grave, y que lo continúan los seis Contrabajos. A ello se unen útiles sonoros que reafirman la descripción del descenso, y otros útiles sonoros proyectan voces inauditas (vos transformada), expresando la existencia de animales extraños, o seres infrahumanos y sus voces moustrosas. En la Ascensión, se emplean útiles de gran transparencia, de sonido ingravido (Aluminios, armónicos en glissados ascendentes(cuerdas) y voces femeninas en ascenso.
 - Se apoyó en la obra musical “Los negros violines de Dubus”, tratando de evocar y expresar en la manera más fiel posible, el contenido literario. Según el texto referido que está en el libro “Los raros” de Rubén Darío, realizada en 1905, “Los Violines también se callan, los violines que tocan tan vigorosamente para la danza, para la danza de las pasiones; los
-

violines se callan también...” la música ha sido compuesta para diez violines, y la fidelidad y apego al texto fué realizada. Así como en la poesía de Eduardo Dubus

- Se han realizado los ensayos respectivos y la preparación de los útiles sonoros necesarios: “Rebotrum”, “Multifonalia”, “Retrivia”, “Tub-Arc”, veinte voces femeninas: se realizó una labor de excongenia para citar las voces más adecuadas.
- Se realizó diversas reuniones y sesiones, para la organización de horarios y días de los respectivos ensayos. Fueron reunidos alrededor de 20 intérpretes para la obra “inframundo” referidos a utilería sonora. Habiéndose realizado la escogencia de capacidades de interpretación. Asimismo, otra de las reuniones importantes fue con autoridades pertinentes relacionadas al tema y con la dirección musical de la obra.



Joaquín Orellana Mejía



VoBo
Luis Adolfo Mijangos Recinos
Director Técnico III
Dirección General de las Artes
Ministerio de Cultura y Deportes

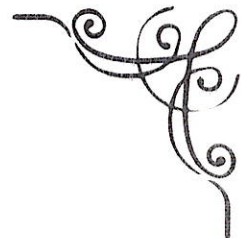
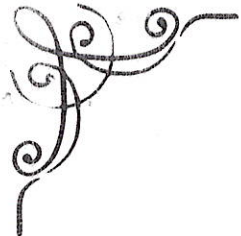

INFRAMUNDO

Descenso / ascensión



Joaquín Orellana

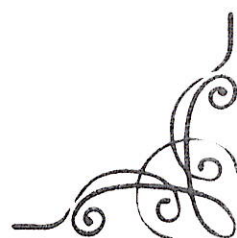

Inframundo

10

B. Dr.

Cellos

Piu mosso ♩ = 75

14

Cirlum

Herron

Pinzafer

Teclambor

B. Dr.

14

Cellos

baqueta blanda de marimba

fp

Meno mosso $\text{♩} = 50$ *rit.* $\text{♩} = 75$

Cellos

D. B.s

The musical score is for page 5 of 'Inframundo'. It features a variety of instruments and includes handwritten annotations. The percussion section includes:

- CF-P (Caja Fumada - Pedal)
- CF-C (Caja Fumada - Caja)
- Hen-an (Hembrado - Anillo)
- Pinzafer (Pinzaferro)
- Resolam Multifonia (Resolam Multifonia)
- Timp (Tambor)
- B. Dr. (Batería)

The string section includes:

- Cellos (Cellos) - 8 staves
- D. B.s (Double Basses) - 5 staves

Handwritten annotations include:

- mf* (mezzo-forte)
- ff* (fortissimo)
- f* (forte)
- mf* (mezzo-forte)
- ff* (fortissimo)
- f* (forte)
- mf* (mezzo-forte)
- ff* (fortissimo)
- ff* (fortissimo)
- ff* (fortissimo)
- ff* (fortissimo)
- ff* (fortissimo)
- ff* (fortissimo)

Other markings include a bracketed *mf* and a circled *mf*. A note in the string section reads: "Sus voces: M fluctuación de 40 de tono". There are also some scribbles in the top right corner of the page.

* Frotados con madera (palo con ranuras)

6

Inframundo

*Los cellos y los contrabajos deben ser tocados apretando la cuerda con un frasco, y se percute con una barra de madera forrada de plástico. Las alturas y ritmos son aleatorios.

The score is divided into two systems. The first system includes:

- CF-A:** Cello with a tremolo effect and *accel.* marking.
- CF-B:** Cello with a tremolo effect.
- CF-C:** Cello with a tremolo effect and *accel.* marking.
- Circumai:** A circular percussive instrument.
- Herroin:** A string instrument with *frotado* (bowed) markings.
- Pinzafer:** A string instrument with *frotado* markings.
- Resolam Multitonalia:** A string instrument with a fretboard diagram showing notes A, M, and G. It includes a *falsete modulado* section and a *dao uv ci a* section.
- Tarros:** A percussive instrument.

The second system features:

- Cellos:** A group of eight cello staves, each with a *gliss.* marking.
- D. B. s:** A group of three double bass staves.

Handwritten annotations include *Pacha* and *mut. ca* in blue ink. Measure numbers 10, 20, and 30* are indicated at the top of the score.

The score is divided into two systems. The first system includes:

- CF-A**: Flute with a box icon and a treble clef staff.
- CF-B**: Flute with a box icon and a treble clef staff.
- CF-C**: Flute with a box icon and a treble clef staff.
- Circular**: A circular icon representing a percussion instrument.
- Heroin**: A heroin icon representing a percussion instrument.
- Multitún**: A multitún icon representing a percussion instrument.
- Pinzafer**: A pinzafer icon representing a percussion instrument.
- Resolam Multifonata**: A Resolam Multifonata icon and a staff with notes labeled 'A', 'M', 'G', 'uv', and 'diuov'.

The second system includes:

- Cellos**: A group of four cello staves.
- D. B.s**: A group of four double bass staves.

Handwritten annotations in blue ink include:

- Invasión* and *Rebotiva* with arrows pointing to the string parts.
- cuerda de piano* and *frotado* near the string staves.
- simil ad libitum* above the first cello staff.
- gliss.* above the double bass staves.

Rehearsal mark **58** is present at the beginning of both systems.

66

CF-A

breve

gliss.

p cresc. densif.

Herroín

Lenguatón

Pinzafer

breve

frotado

f

Rebotrun

Tarros

66

Timp.

breve

66

dietro il pont.

breve

gliss.

gliss.

p cresc. densif.

simil aleatorio

simil aleatorio

densif.

breve

D. B.s

69

Heroin

Pinzafer

PreAr

69

Timp.

69

B. Dr.

frotado con cepillo

f

69

hablado en murmullo

f *dimin.*

ahsaliv tróem tróem irubash

f *dimin.*

ushiv shalaish dula dáim

f *dimin.*

duldáim ladáim ulaish

f *dimin.*

69

D. B.s

The score is divided into two main sections. The first section, starting at measure 71, features a complex arrangement of instruments: Barboxa, Cirina, Herroin, Imbaluas, PreAr, Prehumulinos, Sonarumbas, Termida, and Ululantes I. Each instrument part is represented by a unique icon and a series of rhythmic or melodic symbols. The second section, starting at measure 72, features a vocal ensemble (D.B.s) with six parts, each with Hebrew lyrics and a dynamic marking of *f*. The lyrics are: *ahsaliv tróem tróem*, *ushiv duladáim*, *daím shalaish*, *daladáim ushiv*, *tróem ashaliv*, and *shalasih ushiv tróem*. The score also includes parts for Tmp. and B. Dr. at the beginning of the second section.

Inframundo

Lento

Allegro ♩ = 100

CF-B

CF-C

Circunari

Culum

Herron

Imbalunas

Lenguaton

Pinzafer

Prehimulinhos

Resolam Multifonalia

Termidia

Ululantes I

Ululantes II

Timp

D. B. s

un chelo no divisi
idem los demás

idem cada uno de los
otros 7

gliss. lento

f

gliss. lento

f

gliss. lento

f

frotado

A
M
G

78

CF-B

CF-C

Cirium

Herroin

Pinzafer

Resolam Multifonalia

78

Timp.

78

B. Dr.

78

Cellos

gliss.

gliss. lento

gliss lento

D. B.s

78

81

Estribel I

Pinzafer

Soprano

81

Timp.

81

B. Dr.

81

divisi

Cellos

81

pizz.

D. B.s

pizz.

pizz.

The musical score is for a piece titled "Inframundo" on page 14. It features seven staves: Estribel I (with a graphic of a triangle and a line), Pinzafer (with a graphic of a triangle and a line), Soprano (with a vocal line), Timp. (Timpani), B. Dr. (Bass Drum), Cellos (three staves), and D. B.s (Double Basses, three staves). The score begins at measure 81. The key signature has one flat (B-flat), and the time signature is 4/4. The Soprano part has a melodic line with a fermata over the final note. The Cellos and D. B.s parts have a rhythmic pattern of quarter notes, with the D. B.s parts marked "pizz." (pizzicato) in the final measure. The score ends at measure 84.

85

Barbusá

G. Cirlum

Pre-L

S

Alto

85

Timp.

85

B. Dr.

85

Cellos

pizz.

85

D. B.s

pizz.

pizz.

pizz.

gliss.

The musical score is arranged in a vertical stack of staves. At the top, there are three percussion staves: Barbusá (a large drum), G. Cirlum (a smaller drum), and Pre-L (a triangle). Below these are the vocal staves for Soprano (S) and Alto. The Alto staff includes a 'gliss.' marking. The percussion section continues with Timp. (Timpani), B. Dr. (Bass Drum), and a set of three Cellos. The string section consists of three Double Basses (D. B.s), each with a 'pizz.' (pizzicato) marking. The score is divided into measures by vertical bar lines, with a key signature change from 3/4 to 4/4 in the second measure. Dynamic markings like '85' are placed at the beginning of several staves.

90

Cirlum



Handwritten musical notation for Cirlum, including rhythmic patterns and melodic lines.

Impomperia



Handwritten musical notation for Impomperia, featuring a jagged, sawtooth-like waveform.

Periomín



Handwritten musical notation for Periomín, consisting of a series of dots and curved lines.

Pre-I.



Handwritten musical notation for Pre-I., showing teardrop-shaped notes.

Tubarc



Handwritten musical notation for Tubarc, including horizontal lines and curved shapes.

S

Standard musical notation for voice (S) in treble clef, showing a few notes.

90

Timp.

Standard musical notation for timpani (Timp.) in bass clef, showing rests.

90

B. Dr.

Standard musical notation for bass drum (B. Dr.) in bass clef, showing rests.

90

Cellos

Standard musical notation for cellos (Cellos) in treble clef, showing a sustained note with a fermata.

D. B.s

Standard musical notation for double basses (D. B.s) in bass clef, showing rests.

Transcripción por Francisco José Bustamante

Iconografía de Útiles Sonoros

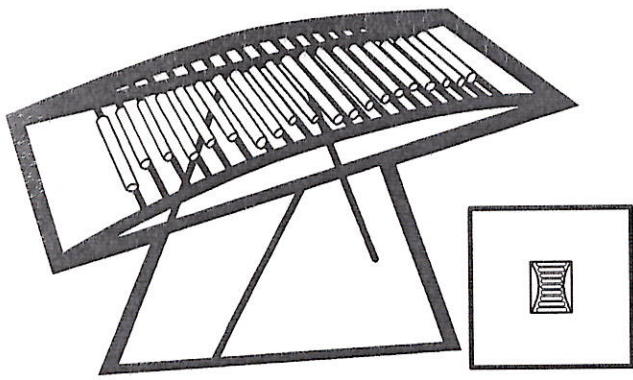

Burbuxá

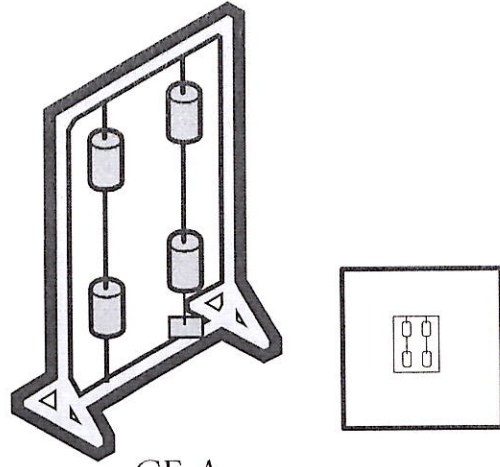

CF-A

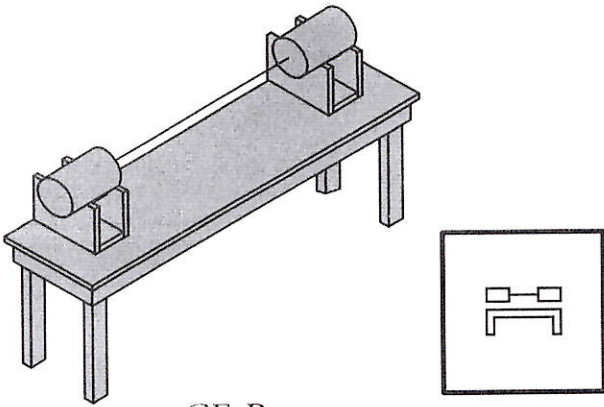

CF-B

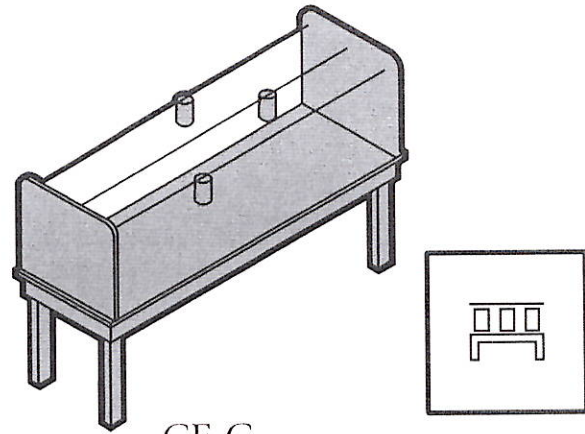

CF-C

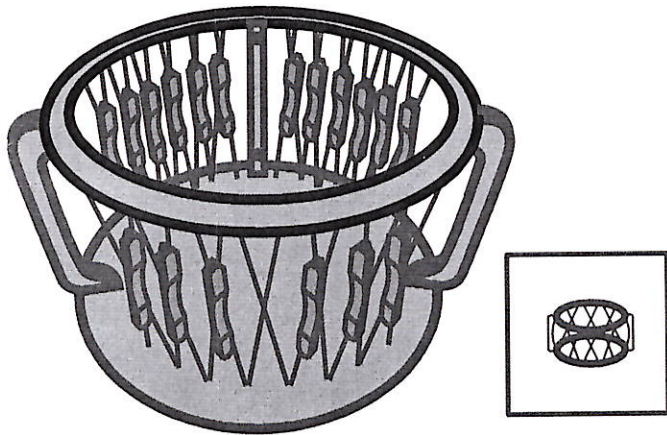

Circumar

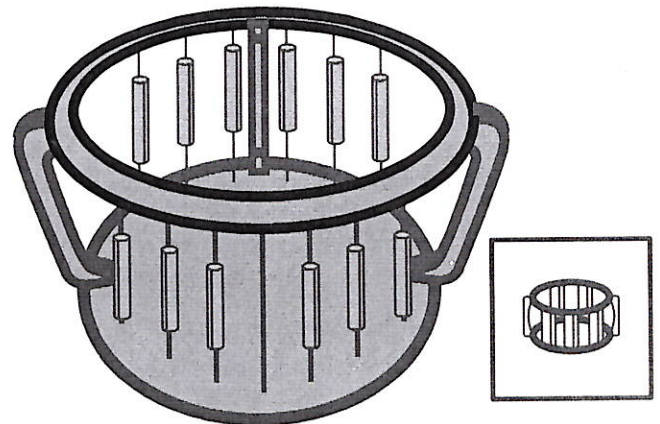

Cirlum

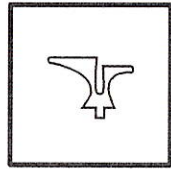
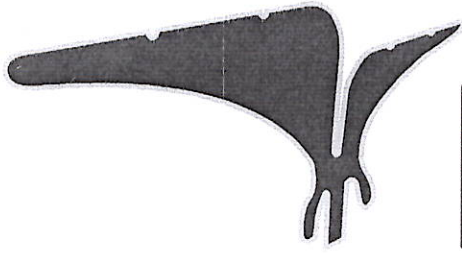

Herroín



Imbaluna

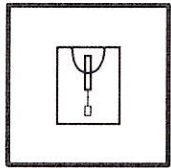
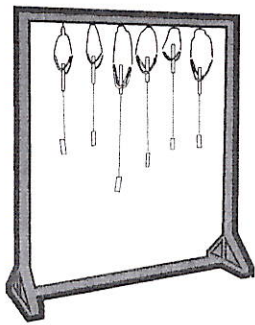

Impomperia

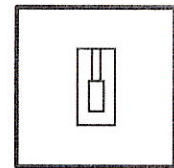
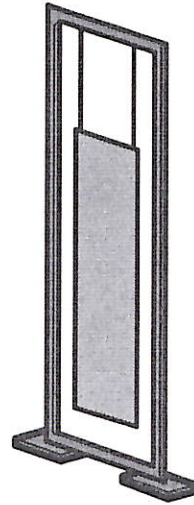

Lenguatón

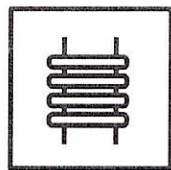
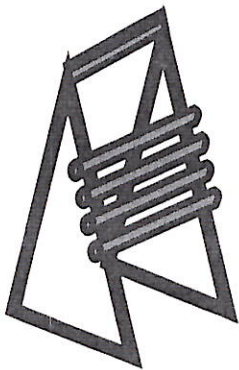

Multitún

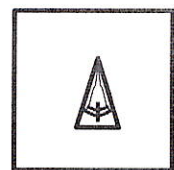
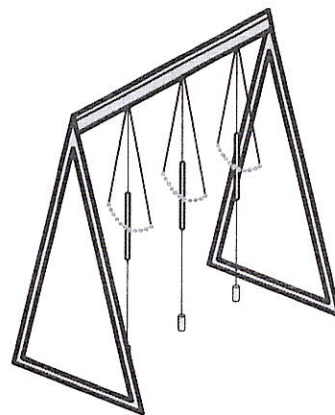

Periomín

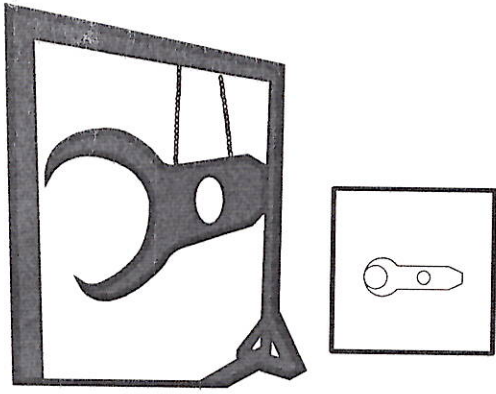

Pinzafer

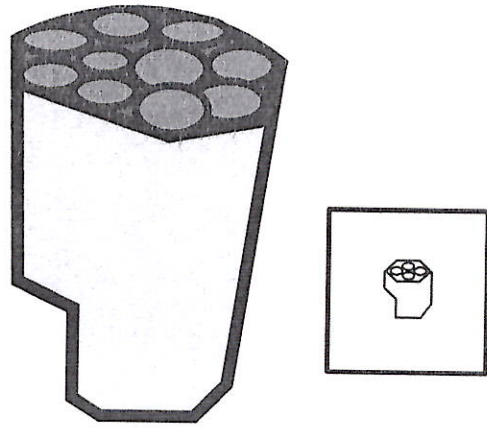

Pre-Ar

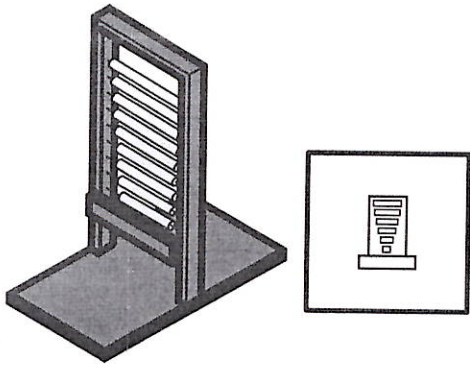

Prehimulinhos

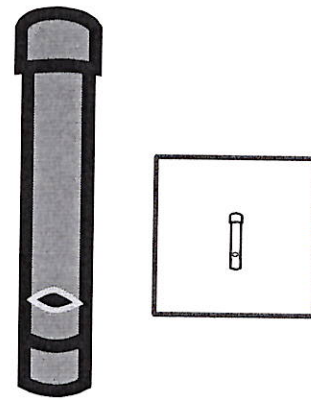

Pre-L

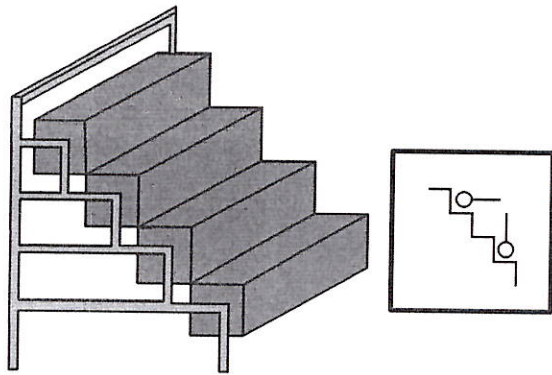

Rebotrún

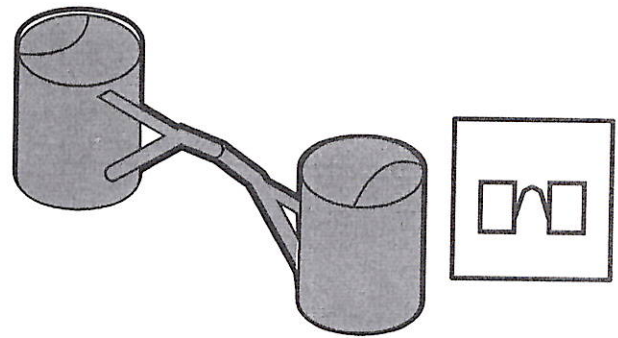

Multifonalia

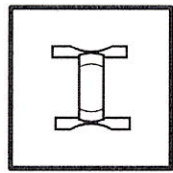
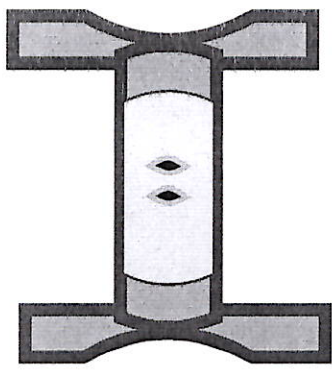

Sonarimba

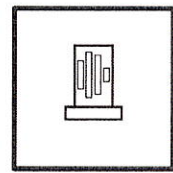
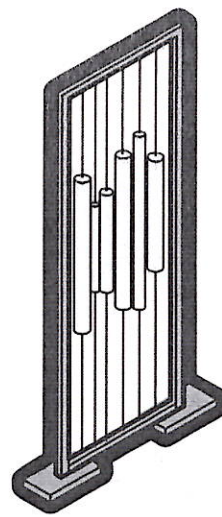

Tarros

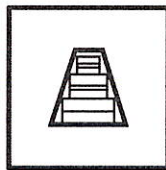
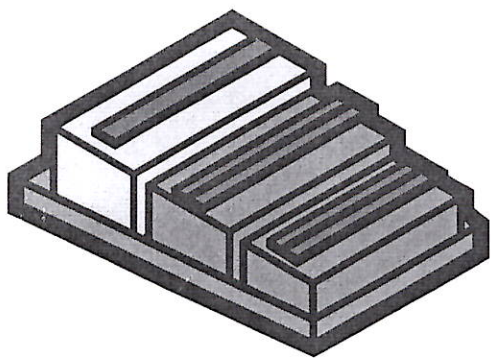

Teclambor

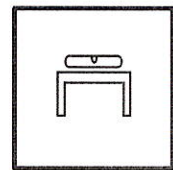
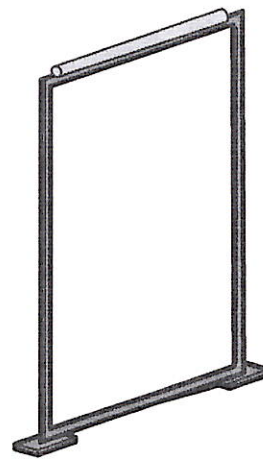

Tubarc

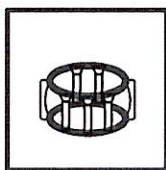
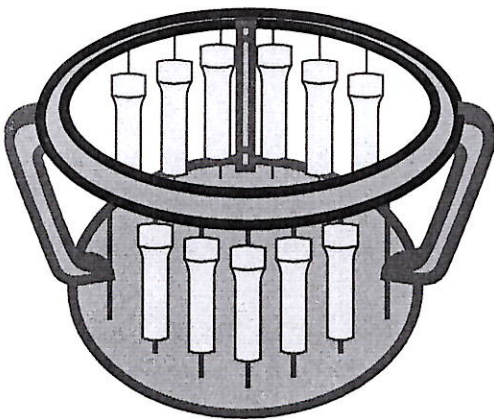

Ululantes I

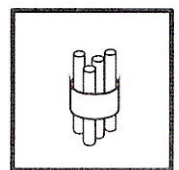
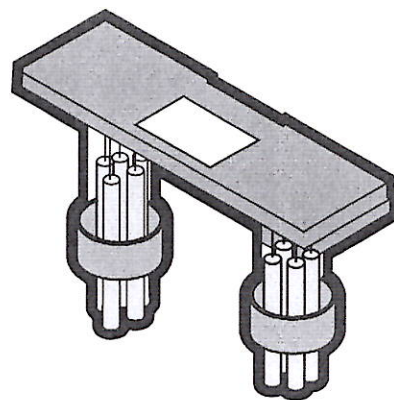

Ululantes II

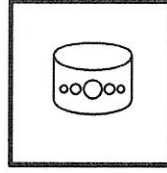
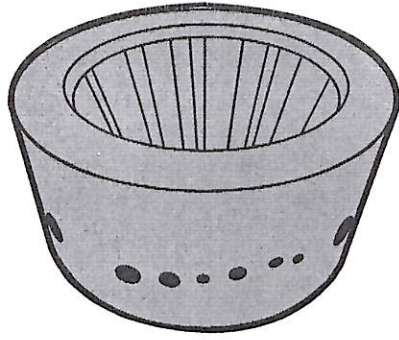

Termidia



Lic. Luis Adolfo Mijangos Recinos
Director Técnico III
Dirección General de las Artes
Ministerio de Cultura y Deportes

Dr. Diaz

» Nov. 2021

Bosquejo X

« Los negros Violines de Dubas »
(10 violines)

4/4

"Lautremont"

J. Durillon

Una interpretación de Los Misteriosos Cantos de Mandarín

Handwritten musical score for piano, consisting of five systems of staves. The first system is marked "Poco ten." and includes a treble and bass clef staff with notes and accidentals. The second system includes a treble and bass clef staff with notes and accidentals, and a section of the bass staff that is crossed out with a large 'X'. The third system includes a treble and bass clef staff with notes and accidentals. The fourth system is heavily scribbled over with dark ink, obscuring the original notation. The fifth system includes a treble and bass clef staff with notes and accidentals.

Lautremont.

(Nemo Violini)

Handwritten musical staves, mostly blank, with some faint pencil markings and a few scattered notes, likely representing a second version or a different part of the composition.